

# T41E Jockey Pump Submittal Sheet

## Performance Curve

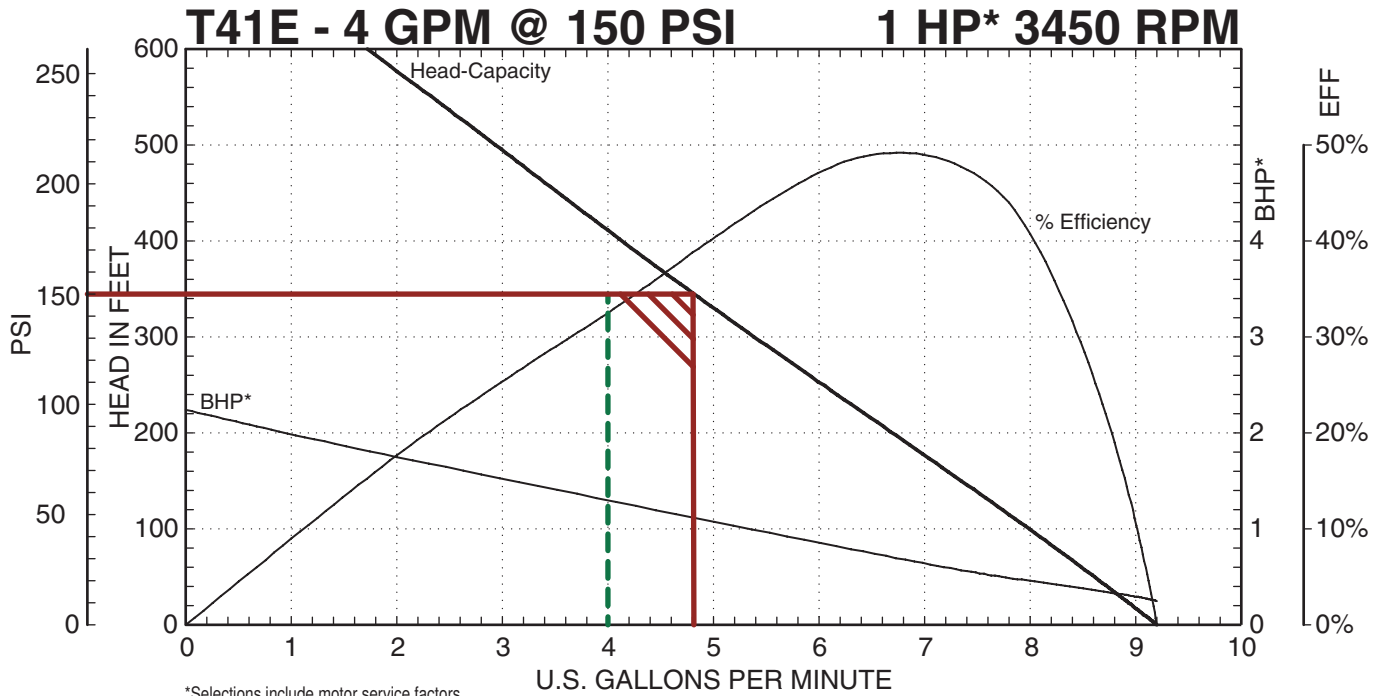

## Dimensions

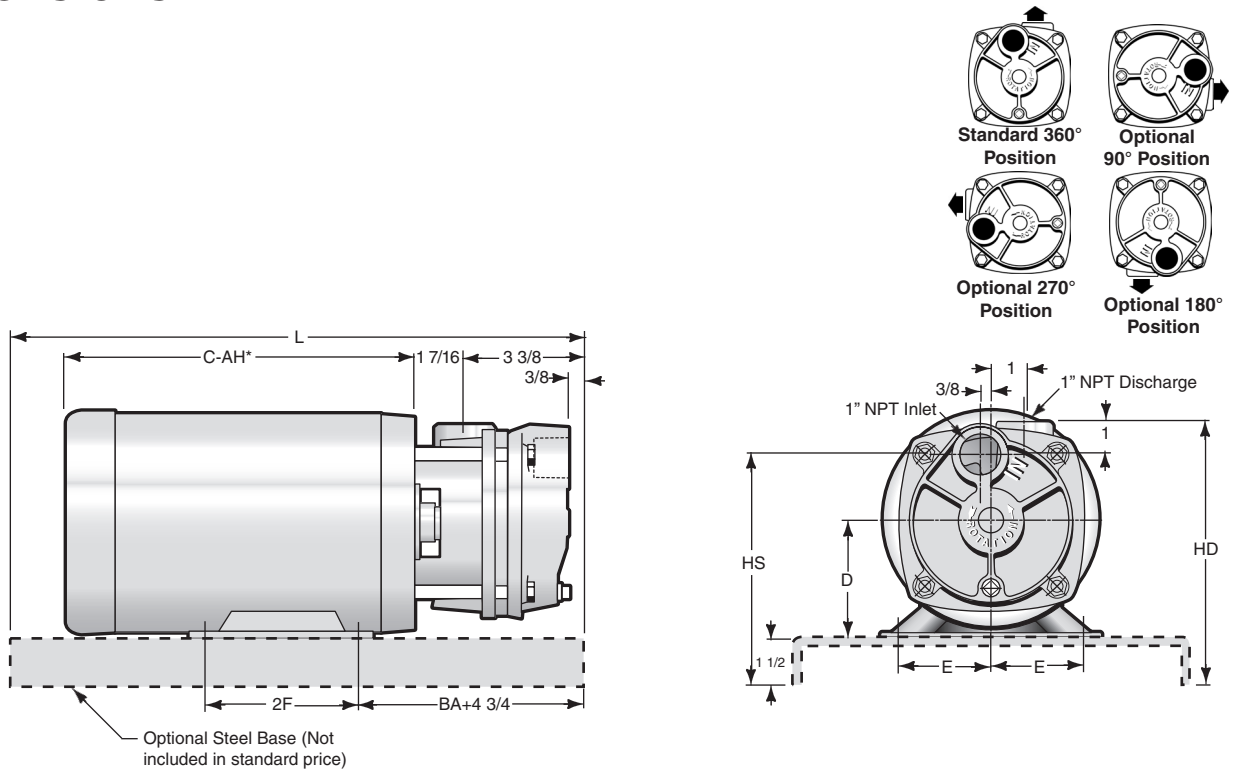

### 1 Horepower Motor Dimensions

FRAME	D	BA+4 3/4	2F	E	H	HS	HD	L
56 C	3 1/2	7 3/8	3	2 7/16	5/16 - 18	7	8	18

#### NOTES

All dimensions in inches. May vary  $\pm 1/4$  inches.  
 Not for construction purposes unless certified.  
 \*See motor dimensions for "C-AH" dimension  
 (Varies depending on motor enclosure).

© Copyright 2019 MTH Tool Company, Inc.



401 West Main Street • Plano, IL 60545-1436  
 Phone: 630-552-4115 • Fax: 630-552-3688  
 Email: SALES@MTHPUMPS.COM  
<http://WWW.MTHPUMPS.COM>

Dated February 2019

# Horizontal Close Coupled Design Specifications

The contractor shall furnish (and install as shown on the plans) an MTH T41 Series horizontal close coupled regenerative turbine type pump model T41E size 1" by 1" of bronze fitted construction. Each pump shall have a capacity of \_\_\_\_GPM when operating at a total PSI of \_\_\_\_\_. Suction pressure will be \_\_\_\_feet with a liquid temperature of \_\_\_\_°F.

The pump is to be furnished with a mechanical seal with stainless steel metal parts, Buna elastomers, ceramic seat and carbon washer. A stainless steel shaft or a shaft sleeve shall be furnished in pumps up to three horsepower and a 316 stainless steel shaft in pumps five horsepower and larger.

The pump casing shall be vertically split two piece, end suction and top discharge with water passageways accurately machined into each piece. The impeller shall be hydraulically self centering and no external adjustment shall be necessary.

The pump shall be close coupled to a standard NEMA "C" face 1 HP \_\_\_\_phase \_\_\_\_Hertz \_\_\_\_voltage \_\_\_\_RPM horizontal open drip proof motor. The motor shall be sized to prevent overloading at the highest head condition listed in the specifications.

## 1-Phase Bills of Materials

Item ID: 8C-T410EBFSCXSAXX-C011AD		
Item Description: T410E BF T21 Cer C/C 3/4 HP 1/60/115/208-230V 3450 RPM ODP Motor		
Item Number	Description	Qty Needed
12-1068-01-457	Type 21 Rotating Element .875" Buna Seal	1
1-2216-0E-543	T41 E Motor Bracket, Teflon Coated	1
2-2206-0E-543	T41 E Cover, Teflon Coated	1
17-1390-01-181	Sleeve, Shaft, Brass	1
15-1168-01-104	Setscrew, 18-8 SS	2
125-1282-01-592	Seal Seat, 0.875 Ceramic, O-Ring Style	1
22-4265-01-101	Plug, 1/8 SAE	1
135-1179-01-457	O-ring, -218 Buna Included w/ Seat	1
7-3970-01-457	O Ring, .902 Buna (Drain Plug)	1
7-2479-01-457	O Ring, -159 Buna	1
DLC-1246-01-ODP	Motor, 56C-Face, DLT Electric, 1 Hp, 1 Phase, 2 Poles, ODP CC	1
19-1997-01-080	Machine Bolt, 3/8-16 + 4"L	4
23-1487-01-080	Key, Sleeve	1
11-2226-0E-206	Impeller, T41E Bronze	1
23-1022-01-104	Drive Key, 316SS	1
14-1049-01-080	Drive Collar	1

## 1-Phase Motor Nameplate

DLT Electric, LLC  
202 West Main Street • Plano, IL 60545

HP 1	SF 1.40	PH 1
HZ 60	RPM 3450	INS B
VAC 115/208-230	FR 56C	MAX AMB 40C
FLA 12.2/6.2-6.1	ENC ODP	KVA CODE P
SFA 16.6/8.4-7.8	DUTY CONT	

PN: DL-C-1246-01-ODP-G SN: C09-UL-10

**Connections**

LOW VOLTAGE UNGROUNDING: WHITE LINE, BLACK LINE, BLUE LINE, RED LINE. HIGH VOLTAGE: WHITE LINE, BLACK LINE, BLUE LINE, RED LINE, BROWN LINE, ISOLATED POCKET.

Rotation is ODP facing shaft end to reverse rotation switch red and black leads.

**WARNING**  
ALWAYS DISCONNECT MOTOR FROM POWER BEFORE SERVICING  
THERMALLY PROTECTED AUTOMATIC RESET  
MOTOR WILL RESTART WITHOUT WARNING AFTER PROTECTOR TRIPS. DO NOT INSTALL THIS MOTOR ON EQUIPMENT WHERE AUTOMATIC START UP COULD RESULT IN INJURY

**GROUNDING**  
FATAL ELECTRICAL SHOCK MAY RESULT IF MOTOR FRAME AND ADJACENT METAL IS NOT GROUNDED IN COMPLIANCE WITH ELECTRICAL CODE.

NOTE: NUT REQUIRED WITH CONDUIT FITTING

CE RoHS MADE IN CHINA

## 3-Phase Bills of Materials

Item ID: 8C-T410EBFSCXSAXX-C019ED		
Item Description: T410E BF T21 Cer C/C 3/4 HP 3/60/208-230/460V 3450 RPM ODP motor		
Item Number	Description	Qty Needed
12-1068-01-457	Type 21 Rotating Element .875" Buna Seal	1
1-2216-0E-543	T41 E Motor Bracket, Teflon Coated	1
2-2206-0E-543	T41 E Cover, Teflon Coated	1
17-1390-01-181	Sleeve, Shaft, Brass	1
15-1168-01-104	Setscrew, 18-8 SS	2
125-1282-01-592	Seal Seat, 0.875 Ceramic, O-Ring Style	1
22-4265-01-101	Plug, 1/8 SAE	1
135-1179-01-457	O-ring, -218 Buna Included w/ Seat	1
7-3970-01-457	O Ring, .902 Buna (Drain Plug)	1
7-2479-01-457	O Ring, -159 Buna	1
FRC-1254-01-ODP	1 HP 3/60/230/460V 3450 RPM ODP Bluffton [3/50/190/380-2880]	1
19-1997-01-080	Machine Bolt, 3/8-16 + 4"L	4
23-1487-01-080	Key, Sleeve	1
11-2226-0E-206	Impeller, T41E Bronze	1
23-1022-01-104	Drive Key, 316SS	1
14-1049-01-080	Drive Collar	1

## 3-Phase Motor Nameplate

**BLUFFTON MOTOR WORKS**

410 E. Spring St. Bluffton, Indiana 46714

Blank

MOD 1303017167  
REF 1254-01-ODP

60 HZ		50 HZ			
HP 1	1	FR 56C	PH 3		
RPM 3450	2875	INS 40	INS B		
V 208-230/460	190-220/380-440	ENC D P			
FLA 3.0-2.8/1.4	3.2-3.0/1.6-1.5	TIME RATE CONT			
SF 1.4	1.0	KVA CODE L			
SFA 3.9-3.6/1.8	Blank	DATE CODE			

**LOW VOLTAGE**

**HIGH VOLTAGE**

**WARNING** - Always disconnect motor from power supply before servicing.  
**MOTOR CONTAINS NO THERMAL PROTECTOR** - Separate over current protection must be provided to prevent burnout and possible fire hazard from overload or stalled motor.  
**GROUNDING** - Fatal electrical shock may result if motor frame and adjacent metal are not grounded in compliance with electrical code.



401 West Main Street • Plano, IL 60545-1436  
Phone: 630-552-4115 • Fax: 630-552-3688  
Email: SALES@MTHPUMPS.COM  
http://WWW.MTHPUMPS.COM